

These drawings and specifications are the property of Interconnect Systems Inc., and shall not be reproduced, or copied, or used without prior written permission.

TOP VIEW

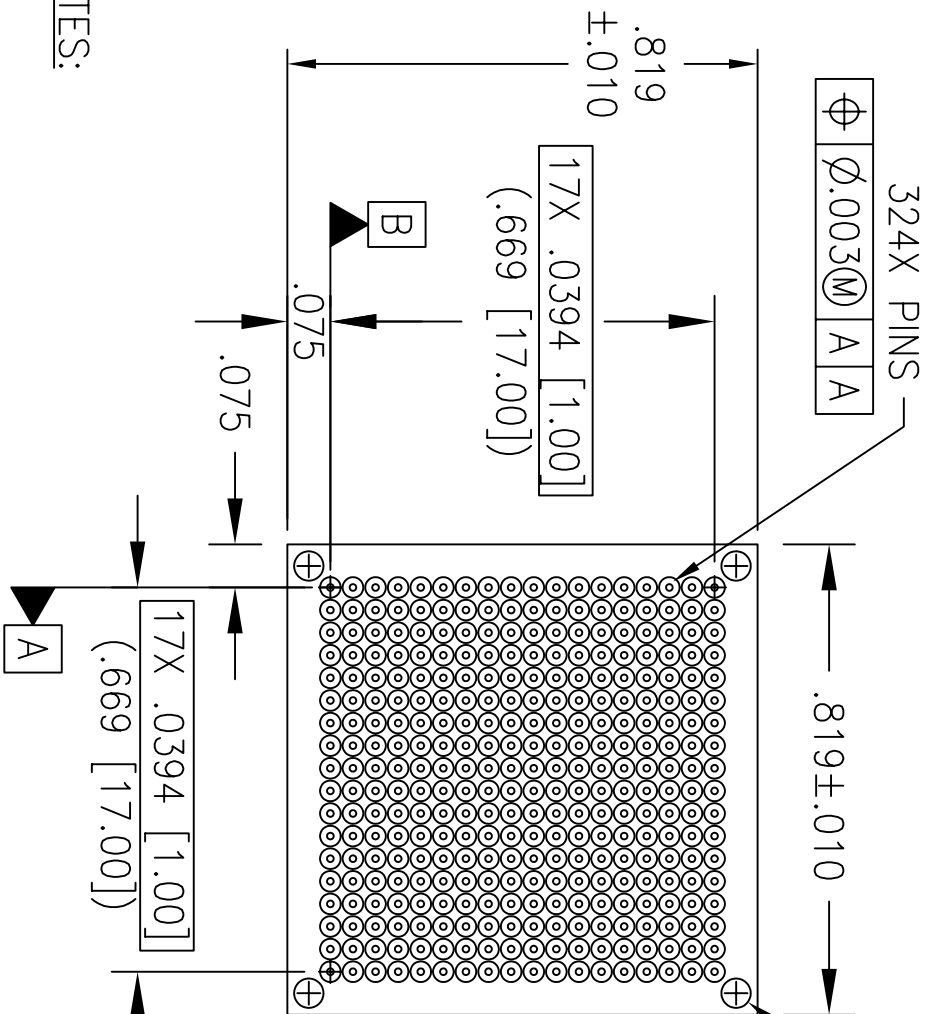

RS VIEW

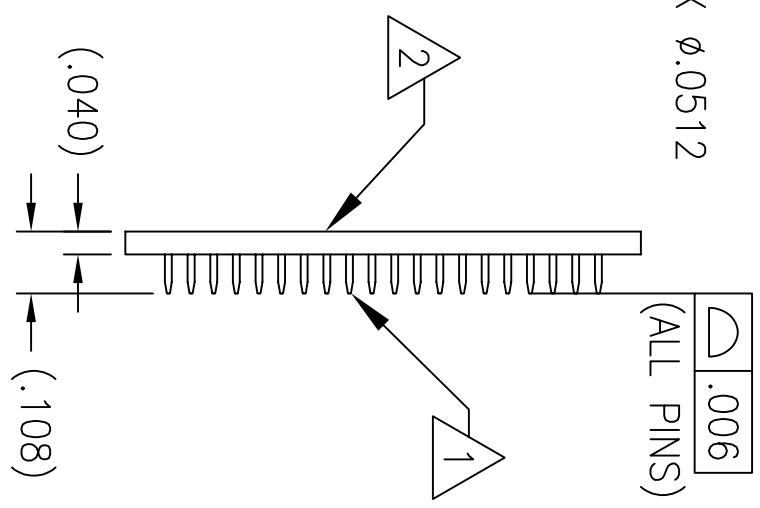

- NOTES:**
- PINS Φ .0117
MATERIAL: PHOSPHOR BRONZE.
PLATING: HARD GOLD OVER NICKEL.
 - INSULATOR MATERIAL: FR4.

| REV | DESCRIPTION | ECN | DATE | RELEASE |
|-----|---------------|-----|------|---------|
| 1 | SALES RELEASE | | | |

| | | | | | |
|-------------------------------|--------------------------|-----------------|----------------|-------------------|--------------|
| CONTRACT NO. | | DATE | | TITLE | |
| DRAWN BY | | DATE | | HIL0-BGA PIN BASE | |
| DESIGNER | | DATE | | 18 X 18, 324 PINS | |
| CHECKER | | DATE | | 1mm PITCH | |
| UNLESS OTHERWISE SPECIFIED: | DIMENSIONS ARE IN INCHES | TOLERANCES: | ± | 1/64 | |
| ANGLES: | FRACTIONS: | DECIMALS: | .XXX | ±.010 | |
| XXX | .XXX | .XXX | ±.005 | | |
| .XXX | ±.0005 | | | | |
| PROCESS ENG. | DATE | DATE | DATE | DATE | DATE |
| SAVED AS: HLP-180324-B-10.DWG | SCALE | DRAWING NO. | FINISHED ASST. | HLP-180324-B-10 | SHEET 1 OF 1 |
| | N/A | HLP-180324-B-10 | | | |

INTERCONNECT SYSTEMS INC.
708 VIA ALONDRA, CAMARILLO, CA 93012